

# APPLICATION OF A TECHNIQUE FOR RESEARCH AND DEVELOPMENT PROGRAM EVALUATION

D. G. Malcolm,\* J. H. Roseboom, C. E. Clark\*

*Booz, Allen and Hamilton, Chicago, Illinois*

and

W. Fazar,

*Special Projects Office, U S Navy, Washington, D C*

(Received April 27, 1959)

This paper describes the development and application of a technique for measuring and controlling development progress for the Polaris Fleet Ballistic Missile program, Special Projects Office, Bureau of Ordnance, U S Navy Project PERT (Program Evaluation Research Task†) was set up to develop, test, and implement a methodology for providing management with integrated and quantitative evaluation of (a) progress to date and the outlook for accomplishing the objectives of the FBM program, (b) validity of established plans and schedules for accomplishing the program objectives, and (c) effects of changes proposed in established plans. In the PERT model, the R and D program is characterized as a network of interrelated events to be achieved in proper ordered sequence. Basic data for the analysis consists of elapsed time estimates for activities which connect dependent events in the network. The time estimates are obtained from responsible technical persons and are subsequently expressed in probability terms. This model is described. Test of the model on a specific component, design of a management control system properly related to existing management systems, reduction to the NORC computer, difficulties in implementation and preliminary results to date are discussed. Limitations of the model, and possible refinements and use of the computer model for testing schedules and for management experimentation in resource and performance tradeoffs are described.

**T**HE THEORY and operating techniques described in this paper were developed for the Program Evaluation Branch of the Special Projects Office (SP) of the Navy. The Special Projects Office is concerned with plans for the development of a complete weapons system. Plans cover research, development, fabrication, testing and production of missiles, guidance systems, ships, and maintenance systems. Training of crews is also scheduled. One group of the Plans and Program Division develops and coordinates plans, and a second group is concerned primarily with costs. The mission of the Program Evaluation Branch of the Plans and

\* Now with System Development Corporation, Santa Monica, California

† Later renamed "Program Evaluation and Review Technique"

Programs Division is to estimate progress to date of the complete system. The objective is the attainment of specifically designated operational capabilities at times some years into the future. This progress estimate includes analyses of the prospects for realizing these capabilities by specific future dates. The Program Evaluation Branch also studies the implications of optional plans involving time, cost, or performance changes in the weapon system.

At the time of the initiation of the study reported in this paper, the position of the Plans and Programs Division was as follows. A schedule for the system development was at hand, encompassing thousands of activities extending years into the future. This schedule had been set up partially to conform to time deadlines set in the light of an urgent requirement for the completed weapon system. This forced some activities to be compressed into uncomfortably short time intervals. Slippages of scheduled dates sometimes occurred. As the Program Evaluation Branch studied the slippages and prospects for future slippages, it appeared that the capacity to predict future progress was more limited than desired. The importance of the issues at stake is great. A study was made of current practice in the evaluation of progress of huge development programs. These practices were not regarded as adequate for the Special Projects problem. Hence a research team was organized to develop techniques for program evaluation of the Fleet Ballistic Missile (FBM) weapon system development. The authors of this paper were the permanent members of the team. Others who participated were RICHARD YOUNG and EVERETT LENNEN, who participated in the early planning stage of the project, FRED LEWIS, who created the computer analysis, and ROBERT PASEK, who aided in the organization of the information flow from the field.\*

The project evaluation research team designated the problem as PERT, the Program Evaluation Research Task. Since the implementation of PERT by the Special Projects Office in 1958, scores of organizations have developed an interest in PERT, several are studying the feasibility of applying PERT techniques within their own operations, and the system is already in operation in a number of industrial concerns and governmental agencies. These events together with further work of the authors have produced extensions of PERT beyond the present FBM application. However, the authors present this paper as a case study in which only the initial PERT operation is described. The initial allocation of time to the project made it imperative that the team develop within a month the general model specification upon which the analysis is based. Hence this paper is a

\* The authors are also indebted to W. F. RABORN, J. W. POCOCK, G. O. PEHRSON, W. F. WHITMORE, L. T. E. THOMPSON, P. WATERMAN, and R. MINER for their encouragement in the course of the project.

case study of the best that could be done in a real situation within tight time constraints by a team of operations analysts

### THE PERT APPROACH

THE PERT team felt that the most important requirement for project evaluation at SP was the provision of detailed, well-considered estimates of the time constraints on future activities. Hence it seemed imperative that for each planned activity, no matter how far into the future, a carefully considered time estimate must be obtained. The qualifications of a person making such an estimate must include a thorough understanding of the work to be done. Furthermore, the time estimates for some activities, such as research and development, are highly uncertain. This uncertainty must be exposed. Ideally, for each activity we should have a probability distribution of the times that the activity might require. As explained below, we focused attention on a few parameters of the distribution such as the range.

Another requirement was for precise knowledge of the sequencing required or planned in the performance of activities. If a specific step in one activity can not be completed until a specific step in another activity is completed, this fact must be considered.

The PERT team planned and activated procedures for obtaining the required information. With this information, one can estimate the time at which each milestone in the system development can be expected. The uncertainty in this time is also estimated. The team developed an analytic tool for making the expected time estimates along with their variances. With this tool, one can predict slippage and also estimate the effect of any actual or potential slippage. One can select the 'critical path' of those activities that can not be delayed without jeopardy to the entire program. One can also tailor the detail of results to any level desired by the user. The analytic tool, the data collecting operation, and the outputs are described below.

Project PERT was set up as a three-phase program

1. To perform an operations-research study leading to the design and feasibility test of an evaluation system
2. To make pilot application of the system in selected areas and
3. To implement the system to all applicable parts of the FBM program

The ensuing discussion is organized along these lines

### PHASE 1 DEVELOPMENT OF THE CONCEPT

THE FIRST step in this phase of the project was to create an adequate and valid model of the FBM research and development plan and schedule. It

was determined that an *ordered sequence of events to be achieved* would constitute a valid model of the program. Further, it was assumed that the necessary activities leading to the achievement of an event could be determined. Moreover it was postulated that these activities were conditioned by identifiable product performance requirements and resource applications.

**The Flow Plan**

The flow plan illustrated in Fig. 1 is a graphical representation of the basic model derived. The network of events and activities necessary to accomplish the end objective,  $T_o$  is shown. An 'event,' depicted by circled numbers in Fig. 1, is defined as a distinguishable, unambiguous point in

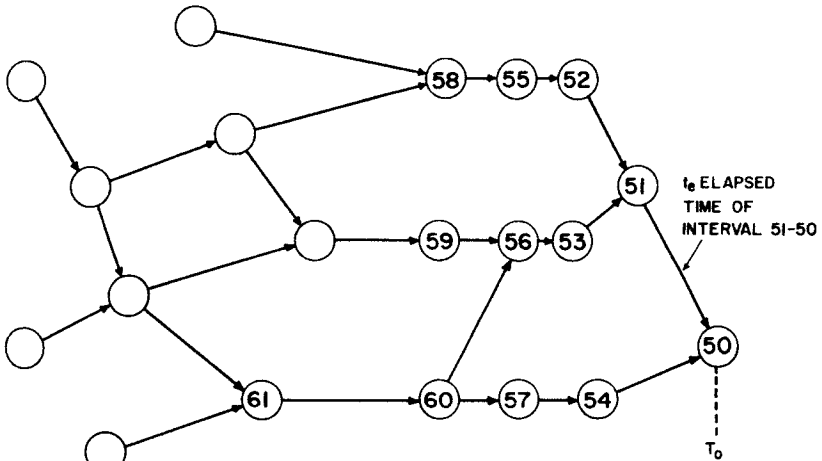

Fig. 1. System flow plan

time that coincides with the beginning and/or end of a specific task or activity in the *R* and *D* process. Wherever an arrow is shown, a completed 'activity' of some sort necessary to achieve the event is indicated. Further, these activities must be performed in proper order as dictated by the network, i.e., activities cannot be initiated according to existing plan until the immediately preceding event has been accomplished.

In this discussion the term 'plan' or 'flow plan' will be used to designate the activities currently envisaged as necessary to the accomplishment of stated objectives. Implicit in this definition is that, for each activity, resources to be applied are known and technical performance expected is specified. When calendar times are set by management and accepted by contractors, a 'schedule' is created. Thus a schedule is defined as a plan with calendar times to reach selected events.

The status of a developmental program at any given time is a function of several variables. These variables are essentially of three kinds: *Resources*, in the form of dollars, or what 'dollars' represent—manpower, materials, and methods of production, *technical performance* of systems, subsystems, and components, and *time*.

Ideally, we should like to evaluate a given actual schedule in terms of all three variables. In this way it would be possible to arrive at an 'optimum' schedule that would properly balance resources, performance, and time. The existence and determination of such an optimum requires that some criterion be analytically maximized or minimized. To do this it is necessary to establish a criterion that integrates time, resources, and performance into meaningful utility. Further, it is necessary that the variables be measurable over all feasible ranges. It is beyond the scope of this paper to discuss the nature and difficulty in furthering such an approach. Suffice to say, that it was determined that no such criterion was available and that the data-processing problems associated with a plan of some 10,000 events would preclude its practical implementation in any case.

Therefore an approach dealing only with the time variable was selected. The effects of resource and technical performance changes enter into the analysis only in regard to their effect on elapsed time for the appropriate activity. As will be seen, this permits a very effective and needed method for including the technical management in the evaluation control process. In addition it makes for an efficient and expedient approach that can be successfully introduced as a management method.

### ***Elapsed-Time Estimates***

With the flow plan laid out graphically and authenticated as representing the work and activities to be performed, elapsed time estimates for each activity are obtained from competent engineers. The symbol  $t_e$  is used to indicate the expected value of an activity in weeks.

In the idealized diagram, Fig 1, it is indicated that there is a value  $t_e$  associated with the interval between events number 50 and number 51. Similar values exist for each arrow (activity) on the chart. These  $t_e$  values are computed from data given by engineers responsible for performing the indicated activity.

Figure 2 is illustrative of the type of diagram used in focusing the consideration of the responsible engineer on the activity whose time is to be estimated. This chart, of size 36×48 inches, has a written description for each event included in the squares. By clearly describing the activity, a minimum of engineering time is required in the estimating process.

In obtaining raw data from the engineers, it was felt that more realistic evaluation could be made if three estimates for each activity were

obtained. This practice was designed to help disassociate the engineer from his built-in knowledge of the existing schedule and to provide more information concerning the inherent difficulties and variability in the activity being estimated. Consequently, three numbers designated as the *optimistic*, *pessimistic*, and *most likely* elapsed time estimates were obtained for each activity. Explicit definitions for each of these estimates were developed and utilized in the interrogation process.

The next task was to translate the engineers' estimates into measures descriptive of expected elapsed time  $t_e$  and the uncertainty involved in that expectation,  $\sigma(t_e)$ . It was postulated that the three estimates could be used to construct a probability distribution of the time expected to

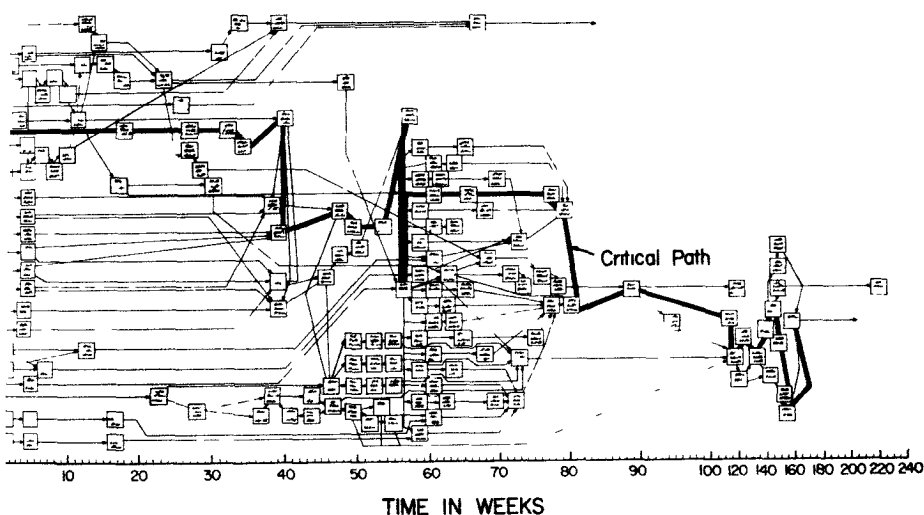

Fig. 2. System flow plan—propulsion component

perform the activity. It was felt that such a distribution would have one peak—with the most probable time estimate,  $m$ , being representative of that value. Similarly, it was assumed that there is relatively little chance that either the optimistic or pessimistic estimates,  $a$  and  $b$ , would be realized. Hence small probabilities are associated with the points  $a$  and  $b$ . No assumption is made about the position of the point  $m$  relative to  $a$  and  $b$ . It is free to take any position between the two extremes, depending entirely on the estimator's judgment.

Figure 3 represents the situation described above. With the assumptions that the standard deviation of the distribution  $\sigma(t_e)$  could be adequately estimated as  $\frac{1}{6}$  of  $(b-a)$  and that the beta distribution,  $f(t) = K(t-a)^\alpha(b-t)^\gamma$ , is an adequate model of the distribution of an ac-

tivity time, it was possible to develop equations for calculating  $t_e$  and  $\sigma^2(t_e)$

$$t_e = \frac{1}{3} [2m + \frac{1}{2}(a+b)], \tag{1}$$

$$\sigma^2(t_e) = [\frac{1}{6}(b-a)]^2 \tag{2}$$

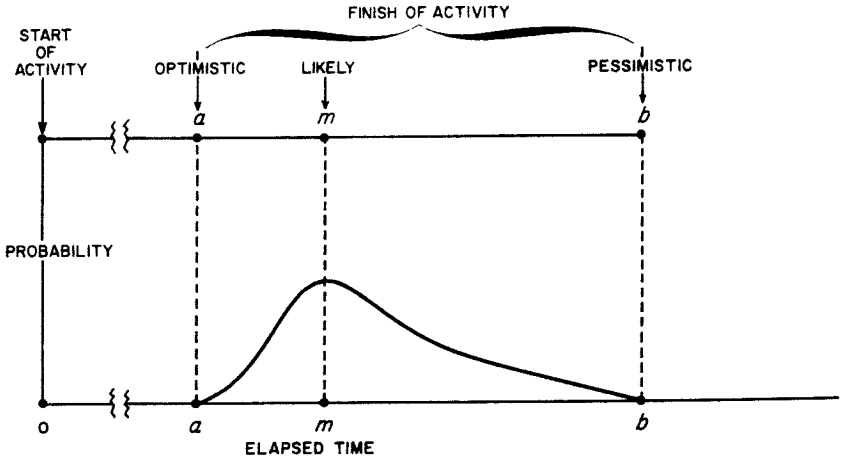

Fig 3. Estimating the elapsed-time distribution

With three elapsed time estimates for each activity in the plan it is then possible to calculate an expected time,  $t_e$  and a measure of its potential variability  $\sigma(t_e)$  for each activity

**Organization of Data**

Once the raw data estimates have been translated into the usable form described above, it is then necessary to structure the information into a pattern which will lend itself to analytical treatment

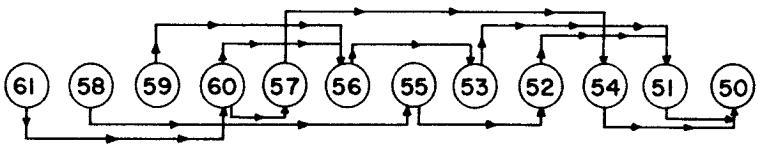

Fig 4 Diagram showing sequenced events

The first step in organizing the data is to order the events in a particular sequence Starting with the last event ( $T_0$  in Fig 1), the events are placed sequentially on a list until the present is reached The only rationale in this ordering is that no event is placed on the list until all of its successors have been first listed This is the equivalent of graphically

collapsing Fig 1—the network—into Fig 4, where the activities (and related events) must logically be performed in the order indicated by the arrows

Figure 5 is a tabular list of these sequenced events, also showing the mean and variance for each activity, computed by equations (1) and (2) It should be noted that an activity is described by the beginning and ending events, e g, activity 50-51 With all events organized in this fashion, it is possible to proceed to the analysis It can be noted, however, that a procedure for sequencing the events has been worked out and programmed on an electronic computer

EVENT NO.	IMMEDIATELY PRECEDING EVENTS			IMMEDIATELY FOLLOWING EVENTS		
	EVENT NO (S)	ELAPSED TIME ESTIMATES		EVENT NO (S)	ELAPSED TIME ESTIMATES	
		MEAN $t_e$	VARIANCE $\sigma_{t_e}^2$		MEAN $t_e$	VARIANCE $\sigma_{t_e}^2$
To 50	51	7	3			
	54	10	4			
51	52	11	4	50	7	3
	53	15	4			
54	57	18	6	50	10	4
52	55	12	7	51	11	4
53	56	10	5	51	15	4
55	58	7	4	52	12	7
56	59	11	5	53	10	5
	60	22	7			
57	60	18	4	54	18	6
60	61	10	5	56	22	7
				57	18	4
.						
.						
.						
NOW						

Fig 5 List of sequenced events

**The Analysis**

The purpose of the analysis is to estimate, for each network event, an expected (mean) calendar time,  $T_E$  of occurrence As will be seen, much more information than this can be developed from the analyses At this point, however, it is convenient to examine the nature of an analysis to arrive at an expected value for  $T_E$  (measured in weeks from time of the analysis)

The mathematician faced with analysis of the network to the above end quickly noted that many difficult analytical situations presented themselves Perhaps illustrative of the problem is one typical situation found embedded in the network



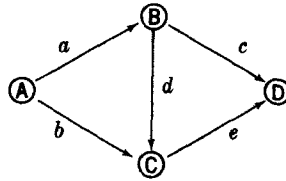

In this case the elapsed time from *A* to *D* is the greatest of the three times  $a+c$ ,  $a+d+e$ , and  $b+e$ , all expressed as probability distributions. Furthermore it is evident that  $a+d+e$  is correlated with each of the other times. Further study indicated that calculative effort for the correlated solution would be exorbitant even with a satisfactory procedure that was designed but not tested.

Therefore, a simplified analysis has been utilized. In this analysis the time constraints of all paths leading up to an event are considered, and the greatest of these expected values is assigned to the event. The variance of this expected value is the sum of the variances associated with each expected value along the longest path.

This simplification gives biased estimates such that the estimated expected time of events are always too small\*. It was felt that, considering the nature of the input data, the utility of other outputs possible from the data and the need for speedy, economical implementation, the method described above was completely satisfactory.

This procedure will now be described in more detail using the data on Fig 5. Figure 6 will be used to describe the outputs available from this analysis.

### ***Computation of 'Expected Times' for Events***

The estimate of the 'expected time' is found in the following manner. Starting at time 'now' (bottom of the list) examine all the activities leading from this event and choose the one with the longest expected time. List this expected time and its associated variance and then proceed forward into the network (up the page in Fig 5) adding elapsed times to expected times established for previous events. As an illustration, the computation of event number 51 will be described in detail.

Figure 5 shows that an event number 51 is immediately preceded by events number 52 and number 53. This exhibit also shows the activity between events number 51 and number 52 has a mean estimated time of 11 weeks, while that between number 51 and number 53 has 15 weeks.

\* The nature of this bias is discussed in an as-yet-unpublished work by C. E. CLARK.

Adding the 11 weeks to the 47 weeks which is the earliest expected time for event number 52 (see Fig 6, column 2) yields an expected time for event number 51 of 58 weeks—insofar as event number 51 depends on the activity that was initiated with event number 52. A similar calculation is made for the expected time for event number 51 as constrained by the activity starting with event number 53. This calculation yields a mean (expectation) of 85 weeks. This time, being the larger, is then recorded as the 'earliest' expected time  $T_E$ , to reach event number 51. The associated variance for event number 51 is found by adding the

EVENT NUMBER	EXPECTED TIMES		LATEST TIMES ( $T_{OL} = T_{OE}$ )		SLACK $T_L - T_E$	ORIGINAL SCHEDULE $T_s^*$	PROB OF MEET G SCHEDULE
	$T_E^*$ EXPECTED	VARIANCE	$T_L^*$ EXPECTED	VARIANCE			
50	92	38	92	0	0	82	05
51	85	35	85	3	0	77	09
54	74	29	82	4	8	73	.42
52	47	25	74	7	27	70	1.00-
53	70	31	70	7	0	60	.04
55	35	18	62	14	27	55	1.00-
56	60	26	60	12	0	50	02
57	56	23	64	10	8	55	42
•	•	•	•	•	•	•	•
•	•	•	•	•	•	•	•
•	•	•	•	•	•	•	•
X-NOW	0	0	•	•	•	•	•

\*(TIME IS SHOWN IN WEEKS FROM X OR TIME "NOW")

Fig. 6. Outputs from analysis

variance for number 53 to that for the activity between number 51 and number 53, or  $31 + 4 = 35$

**Computation of the 'Latest Time' for Events**

It is evident from the above that some events can be accomplished somewhat later than their expected time and still have no effect upon the meeting of some ultimate objective event (event number 50 in the illustration). The latest calendar time at which an event must be accomplished so as not to cause a slippage in meeting a calendar time for accomplishing the objective event is referred to as the 'latest time,' and denoted as  $T_L$ . It is found by fixing the objective event at some future date and working backward through the earlier events. The latest time

for an event, like the expected, exists in the form of a distribution described in terms of its expectation ( $T_L$ ) and variance

The procedure is identical to that described for computation of expected time except that it is started from the objective event (number 50) In Fig 6, event number 50 is anchored at the expected time (for analysis of the feasibility of current schedules it is desirable to anchor at the original schedule date) 92 weeks from time 'now' For example, event number 51 is found by subtracting  $t_e=7$  as shown on Fig 5 and recording the variance of 3

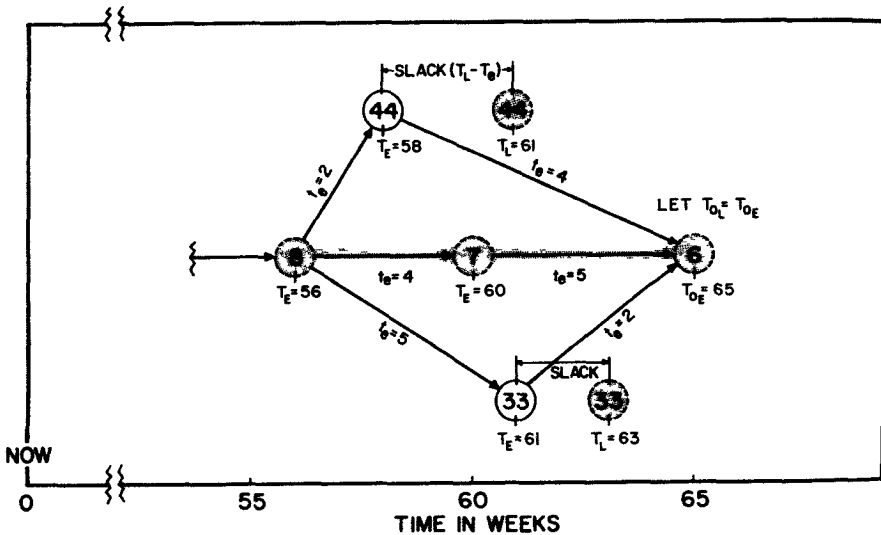

Fig 7 Determination of slack by calculating  $T_L$

### Computation of 'Slack' in the System

Examination of columns (2) and (4) in Fig 6 shows that in some cases there are differences between the latest and the expected times at which an event will occur This difference,  $T_L - T_E$ , is defined as 'slack' Slack can be taken as a measure of scheduling flexibility that is present in a flow plan, and the slack for an event also represents the time interval in which it might reasonably be scheduled

Slack exists in a system as a consequence of multiple path junctures that arise when two or more activities contribute to a third This condition is illustrated in the simplified flow plan shown in Fig 7 This exhibit shows the expected times ( $T_E$ ) for a small complex of events together with the time intervals between them ( $t_e$ ) It can be seen that of the three paths that lead from event number 8 to number 6, the longest expected time of event number 6 is at the 65th week.

If the 65th week is satisfactory for accomplishing the performance of event number 6, the system can be anchored at this point and latest times determined by backward computation as described above. Figure 7 further shows the time relation of the expected and latest times for these events—the dashed circles represent the latest times ( $T_L$ ). This comparison illustrates that events number 44 and number 33 have slack, i.e., events number 44 and number 33 could be scheduled anywhere within their slack range and still not disturb the expectation of timely accomplishment of the final event at week 65.

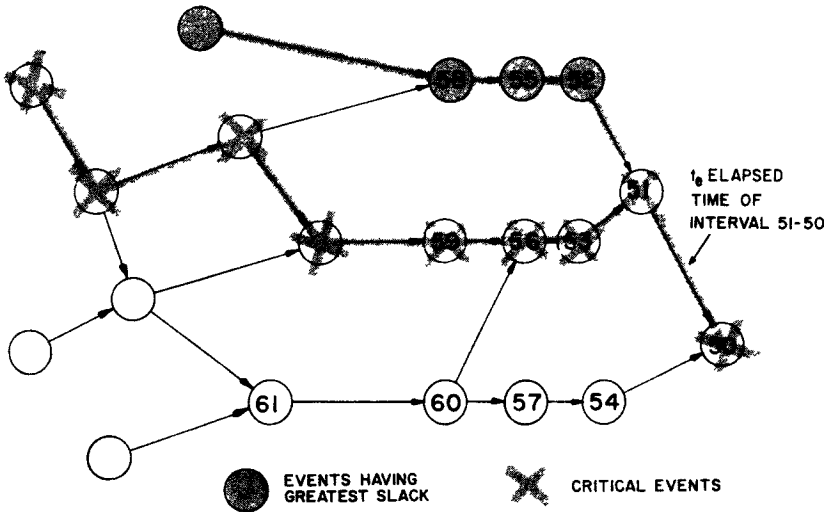

Fig. 8. Critical path in system flow plan

**Identifying the 'Critical Path' in the Network**

The slack for each event in the illustrative example appears in the sixth column of Fig 6. It is noted that, for some of the events, a zero slack condition exists. This indicates that the expected and latest times for these events are identical. If the zero-slack events are joined together, they will form a path that will extend from the present to the final event. This path can be looked upon as 'the critical path'. Should any event on the critical path slip beyond its expected date of accomplishment, then the final event can be expected to slip a similar amount. Figure 8 represents the 'critical path' in the illustrative example. In Fig 8, it is also possible to identify paths having the greatest slack. In this way unprofitable improvements can be rejected since time improvement in these areas produces no, or little, change in the time in achieving the objective. Events on these paths of greatest slack may be examined for possible performance or resource trade-offs.

### Probability of Meeting an Existent Schedule

Utilizing the variances computed as shown in Fig 6, it is possible to estimate the probability of actually meeting scheduled dates Fig 9 shows the last few events of the illustrative example (Fig 1) wherein event number 50 was scheduled at  $T_{os}=82$  weeks The expected time analysis, however, indicated that event number 50 is expected to occur at time  $T_{oe}=92$  weeks with variance  $\sigma^2(T_E)=38$

Utilizing the central-limit theorem, it may be assumed that the probability distribution of times for accomplishing an event can be closely approximated with the normal probability density The probability that event number 50 will have occurred by time  $T_{os}$  is represented on Fig 9 by the shaded area under the curve and is calculated as indicated

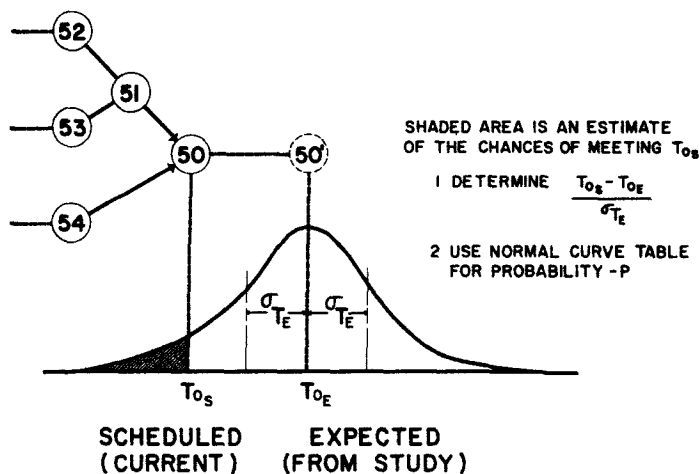

Fig. 9. Estimate of probability of meeting scheduled date,  $T_{0s}$

The last column in Fig 6 shows that this probability is 0.05. Where probabilities assume low values it is reasonable to assume that the schedule is in jeopardy. High values indicate the opposite—that the schedule appears feasible and likely to be met. Technical managers are thus given a number to aid their judgment in reappraising an existent schedule.

### Feasibility Test of the Concept

The above sections have detailed the model, its analysis and the types of outputs available. The next step in Phase 1 was to test the feasibility of the concept as a potential system. This was done by implementing the system on a pilot basis.

The concept as related was applied to the Propulsion Component with the following steps and checks:

1. The flow plan was laid out as shown in Fig 2
2. Elapsed-time estimates were obtained from technical people
3. The analysis as herein described was made
4. The outputs were graphically portrayed and their significance discussed and interpreted
5. The costs of handling the more elaborate structure of a total program on a computer were estimated. Special attention was given to the importance of having a general computer program so that changes in plans could be quickly and easily made

In reviewing the above with the top management of the FBM Program the following points were brought out

1. The technical people interviewed during the course of the project expressed their desire to report the expectations of their work in this manner. Their general reaction was that the estimating of elapsed time was a more realistic way to gauge R and D uncertainties and should therefore provide better information for program evaluation

2. Experience showed that interrogation of technical people could be limited to a few minutes by laying out and obtaining an approved flow plan from regular planning people in the companies involved. By this means the technical man could focus his attention on only the activity to be estimated

3. It was concluded that the PERT concept in real operation would (a) be more accurate than existing evaluation reports in producing an outlook into the future, (b) be practical from the point of view of not requiring exorbitant time from contractor's technical staff, (c) permit developing a management-by-exception approach in FBM technical management, (d) require the use of a flexible computerized system

It was then decided to further test the concept by implementing it on a test basis for four or five components of the missile system out of the total of some 65 components

## PHASE 2 PILOT APPLICATION

IN PHASE 2, three major tasks were involved. The first was to design an operating system for collection of the data, to select reporting periods, to design forms, and the like. The second task included the development of a computer program to perform the necessary analyses and desired output reports. The third task was to develop a program for obtaining the initial inputs and to guide SP management in the use of the technique and of the outputs. In the paragraphs that follow, the system as it was designed and installed during Phase 2 will be described.

Figure 10 depicts the over-all system in operation. As illustrated, the inputs to the PERT system are the flow diagram (which identifies the activities and events in their correct relation) and the elapsed time esti-

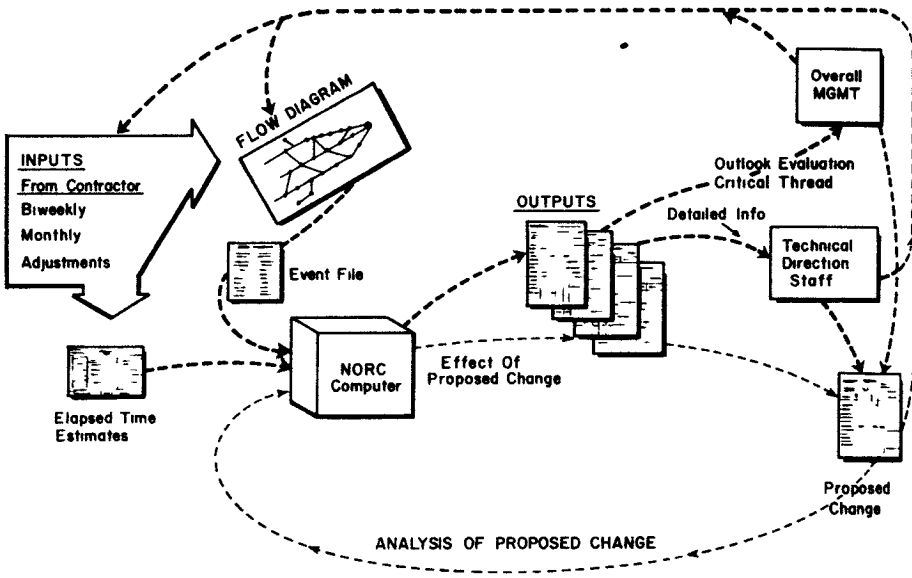

Fig 10 PERT system in operation

mates (which provide periodic updating of information) This information is then introduced into the computer Figure 11 is descriptive of the information contained in the event file at the SP management center Events must be defined unambiguously and be coded in order to utilize the computer Therefore it is not necessary to include the written description of the events in the event file set up at the computing establishment

EVENT IDENTIFICATION FILE			
SUB SYSTEM		27-MISSILE	
COMPONENT		400-BALLISTIC SHELL	
EVENT			
EVENT	PREDECESSOR	SUCCESSOR	DESCRIPTION
27-400 024	27-400-023	27-400 026	Compl Modif, and c/o by Grd Tests Bal Shell
27-400 025	27-400-022	27-400-027	Arrival of Vehicle at PAFB (AIX)
27-400-026	27-400-024	27-400-028	Fit Test Bal Shell (AIX)
27-400-027	27-400-025	27-400-029	Comp
27-400-028	27-400-030		

Fig. 11. Event identification file

### ***Inputs***

A form was designed for obtaining routine information inputs. This particular form was designed to pick up information on a biweekly, monthly, and quarterly basis, and was compatible with the existing milestone reporting system. On a biweekly basis, the contractor is required to report the status of all events that have been completed or scheduled for completion during the previous two weeks. At this time, the contractor is also requested to report concerning any future events that appear to be in jeopardy. This is done by making new elapsed-time estimates for the event in question. In regard to the monthly use of the form, some of the 'management-by-exception' opportunities permitted by the PERT system are exploited. The monthly report calls for specific re-estimate only for those events on critical paths as determined by the previous computer analysis. This also includes subcritical events, where the criteria for defining a subcritical event relates to amount of slack involved in the event. Those events having as much as five weeks slack have been deemed subcritical. In this way the volume of re-estimating has been reduced to a practical minimum.

In the quarterly report, it was decided that it was necessary, periodically, to evaluate the totality of the network, owing to the changing nature of planning activity. The quarterly report requires a reconstruction of the original flow chart complete with re-estimates of activity times. The PERT team from the FBM Management Office is involved in this report. All other reports are initiated by the contractor in accordance with a standard practice that was set up.

### ***Computer Analysis***

As indicated earlier, the requirement for speed in data-processing ability, and the desire to permit management experimentation in the way of performance and resource trade-offs, dictated that the use of a high-speed electronic computer be considered.

After investigating several available computers it was decided to utilize the Naval Ordnance Research Computer (NORC) at the Naval Proving Grounds, Dahlgren, Virginia. The outputs as indicated in the Phase 1 report were found satisfactory and feasible to program.

The challenge in the programming task was to provide a general-purpose model that could accept continuous changes with a high degree of flexibility. These changes come in the form of newly defined activities (and hence new events) and occur for a variety of reasons. Since such changes cannot practically be avoided by 'better' planning, it is necessary that the reasons for change be understood and that the expected volume be considered in



designing the data-processing system. Reasons for changes in planning may be summed up as follows:

(a) Planning into the future is imperfect at best and new interrelations will be continually discovered.

(b) Greater detail in planning is possible as time progresses. The more immediate future can thus be spelled out in greater detail.

(c) The need exists for alternate or back-up activities to improve chances of achieving certain difficult technical achievement on the desired schedule.

It was desired that the anticipated changes could be both simply introduced into the analysis and also that the volume of input data from the biweekly and monthly reports could be handled in the computer. Figure 12 lays out the data-processing approach in broad-block form, indicating the various files that were created to handle the analysis and the required outputs. One important advantage of this approach should be emphasized: a new activity can be added simply by identifying its successor and predecessor. Thus, the computer routine is a general one and is quite flexible in that it can readily accept changes in planning that are expected to occur.

### ***Interpretation of Computer Outputs***

There are three basic outputs of the computer. These outputs include the expected time for the completion of each event, the identification of slack and critical areas in the programs, an expression of the probability of equalling or meeting the current schedule and the specification of the latest date by which every event must be completed in order to meet the end-objective deadline.

Many opportunities exist for organizing these outputs in different ways. In Fig. 6, the various outputs found useful were shown. On the final print-out form (see Fig. 13 for form design), the variance columns were deemed unnecessary. It is also possible and has been found useful to print out only the critical events. In addition, further condensations of these data are made for different levels of management.

### ***Technical-Management Experimentation***

One of the most useful aspects of the NORC outputs is the ability it provides for checking the feasibility of current schedules and for permitting technical management to 'experiment' with or evaluate the effects of proposed changes in the research program under its technical direction. For example, one does not want to make a substantial investment in improving the time in accomplishing a 'slack' event. However, owing to the extreme complexity in thinking in terms of a network, the effect of changes are hard to visualize in terms of their impact on some broad or ultimate objective.

To study changes the technical manager may initiate a 'simulated'

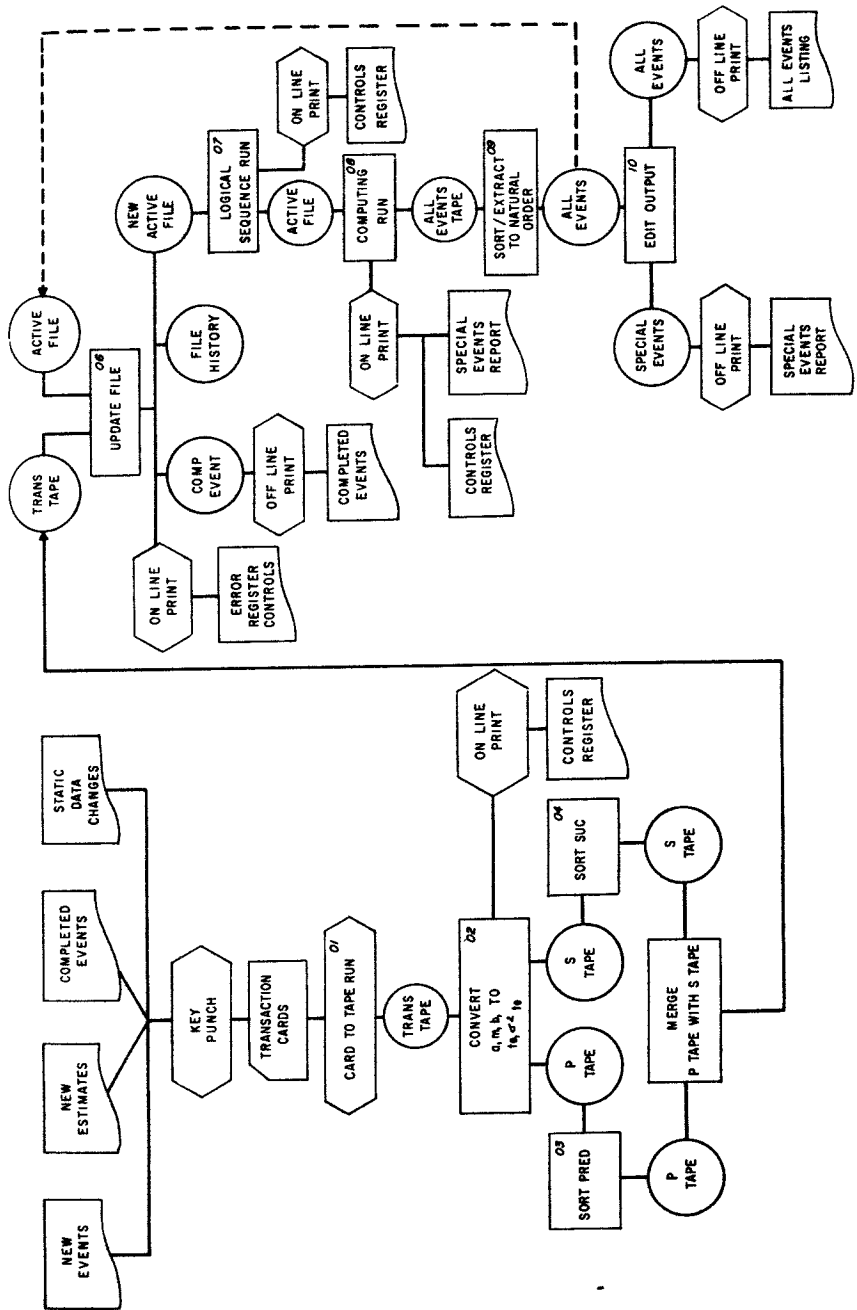

Fig. 12. PERT data-processing flow chart

change in the program by submitting a new estimate for the elapsed time of any given activity to the computer for analysis. Or he may test the impact of a new activity he is planning to create. In proposing these changes, knowledge of the changed technical performance or the changed

PERT SYSTEM		BALLISTIC SHELL COMPONENT - SIMULATED OUTPUT (to determine impact on end-objective of saving time for a preceding event)				
DATE <u>7/12/58</u>		WEEK <u>00</u>			PAGE <u>2</u>	
EVENT	$T_E$	$T_L$	$T_L - T_E$	$T_S$	$P_r$	SCHEDULED DATE
_____	_____	_____	_____	_____	_____	_____
_____	_____	_____	_____	_____	_____	_____
_____	_____	_____	_____	_____	_____	_____
_____	_____	_____	_____	_____	_____	_____
_____	_____	_____	_____	_____	_____	_____
_____	_____	_____	_____	_____	_____	_____
_____	_____	_____	_____	_____	_____	_____
_____	_____	_____	_____	_____	_____	_____
_____	_____	_____	_____	_____	_____	_____
27-400-024	35 0 30 0	35 0 32 0	0 0 2 0	_____	_____	_____
_____	_____	_____	_____	_____	_____	_____
_____	_____	_____	_____	_____	_____	_____
_____	_____	_____	_____	_____	_____	_____
_____	_____	_____	_____	_____	_____	_____
27-400-038	112 109	112 109	0 0 0	_____	_____	_____
_____	_____	_____	_____	_____	_____	_____
_____	_____	_____	_____	_____	_____	_____
_____	_____	_____	_____	_____	_____	_____
_____	_____	_____	_____	_____	_____	_____

ORIGINAL NORC OUTPUT

Activity reduced 5 weeks

SIMULATED NORC OUTPUT

ORIGINAL

Effect on end-objective 3 weeks saved

SIMULATED

Principle

An improvement along the critical path can produce up to the amount of improvement in the expected time for completing the end-objective

Fig 13 Computer output sheet—evaluation of proposed changes

resources applied to the activity must be available. The technical manager receives back a 'simulated' output sheet indicating the effect (timewise) of the proposed change. By comparing the 'costs' with the benefits, he can make or recommend the necessary changes in the program. Figure 13

is descriptive of the kind of output sheet that he may receive as a result of his simulation Principles were developed to aid technical managers in evaluating the effects observed

SAMPLE PERT OUTLOOK FOR MAJOR FBM PROGRAM SUBSYSTEMS

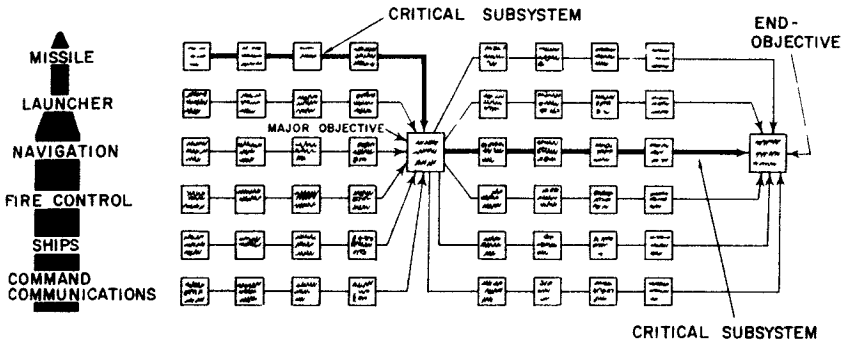

SAMPLE PERT OUTLOOK FOR MISSILE SUBSYSTEM COMPONENTS

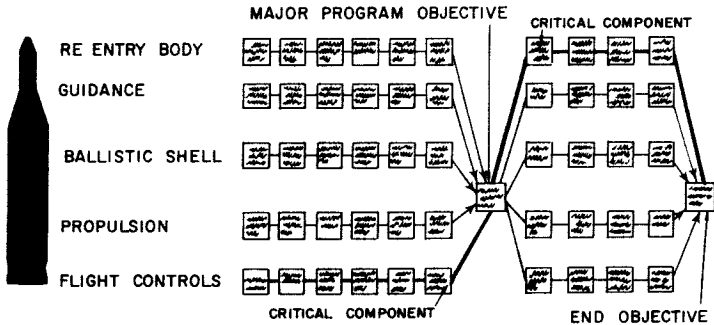

Fig 14 Integrated outlook

**Program-Outlook Information**

In addition to the experimentation mentioned above, it is possible to organize the outputs and interpret the information to management on a weekly or a biweekly updated basis as shown in Figs 14 and 15 It is possible, as shown in Fig 14, to indicate critical components as contrasted with critical events within a component Top management often is more concerned with which broad area of the program is in jeopardy rather than with specific events A reporting system was specially designed for the use of top management In this system, attention is initially focused on

broad areas of interest Detailed back-up can then be provided to explain any questions that arise from consideration of the over-all picture.

The expectations for achieving major events may also be used as a means of portraying the outlook Figure 15 indicates how the expectation is being compared with the current schedule, and how trends in the outlook may be presented to management for its use in obtaining a more quantitative feel concerning the outlook for program accomplishment

### Results of the Pilot Test

The pilot test for three components was accomplished in approximately four months, with computer outputs of the types shown in the preceding figures During this time, analysts were trained in obtaining the necessary

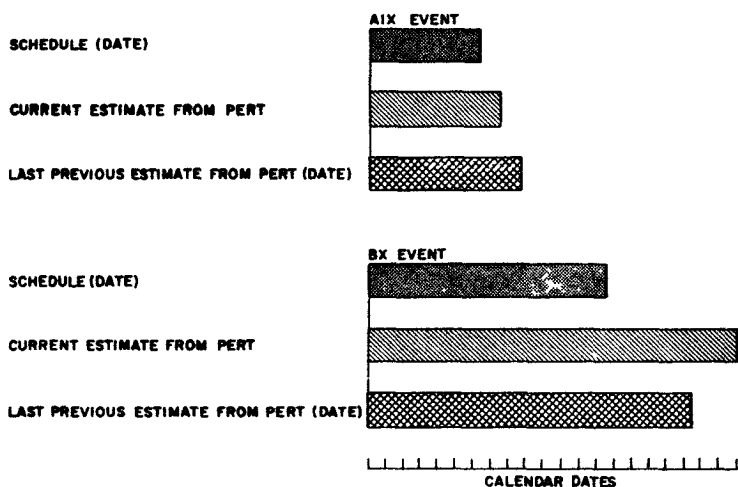

Fig. 15 Major-event outlook

data, preparing the data for the computer inputs, and in interpreting its outputs Technical managers were encouraged to utilize the outputs for experimentation Further, an instructional systems and procedures manual was developed Procedures developed were made compatible with existing information-reporting practice Manning cost and time estimates were made covering the installation and implementation of the system for the entire FBM Program Review of these results led to the decision that the system should be implemented across the basic Polaris weapon system

### PHASE 3 FULL-SCALE IMPLEMENTATION

ONE OF the first tasks in developing an implementation schedule was to get an accurate estimate of the number of components that would be in-

cluded in the system. An analysis of the Phase-2 effort developed the amount of time required to do the various specific tasks in getting the system reduced to practice. It was found, for example, that the set-up time for a new component required 7.3 man-weeks of professional and supervisory time and that maintenance of a component involving the biweekly, monthly, and quarterly reports, required 1.1 man-weeks per month at the Special Projects Office. Then with an estimate of the total number of such 'standard components' in the FBM system and a six-months installation objective, the number of staff required was estimated by skill type.

### ***Some Problems in Installation***

In the course of installing a control system of this complexity many different types of problems are encountered. One of the most perplexing questions facing the system installer concerns the effect of errors in input data. This question is raised by many people, who emphasize that different estimators can be expected to have different degrees of bias. Another fear frequently expressed was the fact that such an evaluation tool might prove too disruptive to the management process in a given company in that it may have a technical man contradicting progress information given by his management. The fear was expressed that as a result an attempt would be made merely to parrot the existing schedule. This action might be of such a serious nature that the inputs would not be sufficiently accurate to allow for any meaningful evaluation.

Turning to the question concerning adjusting of inputs, experience has shown that attempts to modify input data in order to make them more compatible with the equivalents of the existing schedule have not occurred. For one thing, it is not easy to make this adjustment, since the network is so complex that one needs essentially to make the computer analysis itself before he can tell how to modify the elapsed-time estimates. In regard to differences in estimators, correcting provisions are possible: first, an auditing function by technical management at the Washington level, second, a program of comparing estimates with actual performance over a period of time to permit 'calibration' of the estimators. Problems such as the above are to be expected in the installation of any system and can be dealt with. It was found that there was a considerable need to have theoretical discussions concerning the system and to make explanations concerning the practical assumptions that were made in designing the system. In general, when an individual could be involved in the system and be permitted to work with the computer people in terms of making simulated outputs, his confidence in the system and enthusiasm for it improved greatly.

Another question often brought up in connection with a management-

control system relates to the cost and the utility of the system that is designed. Is the information provided worth the costs incurred? In the case of the PERT system, it was felt that the requirement for constant evaluation was so important that the minor cost of the system was definitely justified. However, the general observation can be made that in the long run the value of any control system has always depended on the individuals who use it in making decisions. If they have confidence in the system, and feel that it aids them in the decision process, then there is strong and sufficient testimony as to its worth. This has been the history of the evolution of all management-control systems.

### RESULTS TO DATE AND OUTLOOK FOR THE FUTURE

IN SUMMARY, top management of the Special Projects Office has used PERT analyses in the following ways. The standard periodic computer runs have given convincing indications of the parts of the development program that are most likely to cause serious delays. This knowledge has led to executive actions that have significantly improved outlooks for achieving program deadlines. In these and other cases of administrative decisions, proposed action is first tested by computer runs to obtain quantitative measures of increased probabilities of meeting deadlines or of expected time savings in the complete program. The speed with which the computer analyses can be made is important.

Lower levels of management are responsible for the formulation of recommendations concerning all possible ways to expedite the program. The PERT analyses permit a quantitative evaluation of conceivable alternatives. In addition, the standard runs suggest where improvements should be sought.

The significance of the PERT technique as a tool for advancing management effectiveness can be judged from the results of its application to date and the widespread interest evidenced by a large variety of organizations outside the Special Projects Office. Experience has shown that the system itself is still developmental and has prospects for extension and variation in order to improve and profit management in many ways.

By mid-1959, only 17 months after the research task began, the technique described was in operation to cover most of the FBM weapon system to varying extents for each major category of effort. Twenty-three networks, containing more than 2000 events connected by some 3000 activities, were installed and in operation. Several applications had been directed to major problems requiring prompt executive decisions. Numerous computer runs were made to simulate the impact of options for decision. Many executive actions and decisions based on standard runs and simulation runs resulted in significantly improved outlooks for achieving program

deadlines In one instance, some 25 simulated runs resulted in actions that reduced by two-thirds the initial outlook for exceeding a critical time deadline

Considerable evidence is available of indirect or intangible benefits that accrued to SP and its contractors through application of this technique The drawing and authentication of networks require that SP and the contractors agree on significant progress benchmarks and their sequence and interdependency The obtaining of this agreement among these parties ensures effective communication and coordination, both often assumed or taken for granted In several cases, top management and technicians stated that merely the activity involved in the drawing and maintenance of networks is a profitable procedure for more effective management



Copyright 1959, by INFORMS, all rights reserved. Copyright of Operations Research is the property of INFORMS: Institute for Operations Research and its content may not be copied or emailed to multiple sites or posted to a listserv without the copyright holder's express written permission. However, users may print, download, or email articles for individual use.